

M1 ACTIVE

INSTALLATION MANUAL & USER'S GUIDE

L.R. Baggs

483 N. FRONTAGE RD.
NIPOMO, CA 93444
WWW.LRBAGGS.COM

1. PACKAGE CONTENTS

One (1) M1 Active pickup with battery installed
One (1) pre-wired strapjack assembly
One (1) spare battery
One (1) 3/32" Allen wrench
Two (2) spare 3/4" pole pieces
One (1) spare 3/8" pole piece
Two (2) self-stick wire clips
One (1) manual
One (1) warranty card

2. OVERVIEW AND CAUTIONS

The M1 Active magnetic pickup, with its built-in all Class A discrete preamp, features outstanding body sensitivity with great warmth and presence. Its dual-coil design employs L.R. Baggs' exclusive patent pending Tri-Axial Dynamic Technology to produce clear, rich tones that are resistant to feedback, noise and hum, with string and body sound all in one. A volume control is conveniently located for fingertip control. The M1 Active also features individually adjustable pole pieces with smooth, threadless tops. The M1 Active will fit guitars with sound holes larger than 3.5" that are centered beneath the strings. Ensure that this product will fit the guitar properly before installing the strapjack. The installation procedure is very simple; however, we recommend that any woodworking (for instance, drilling a strapjack hole) be performed by a professional dealer/installer. We do not provide advice or support for home or hobbyist woodworking. Installers: Please read the instructions carefully before proceeding. We will not be responsible for any damage to the guitar or personal injury resulting from installation, improper installation, use or misuse of the product.

3. INSTALLATION

3.1 Strapjack installation: If the guitar doesn't already have a strapjack or a hole in the tail block, it will be necessary to drill one in order to use the strapjack.

This jack requires a clean 1/2" hole in the tail block of the instrument. If the guitar lacks this hole, start by placing a piece of masking tape on the outside of the instrument over the drilling area (to avoid chipping the finish), drill a small pilot hole in the tail block and then follow with a step drill. Now proceed with the installation.

Remove the strap ring, retaining nut and one washer from the end of the jack. There should still be one star locking washer, one flat washer and a nut remaining on the jack. Bring the jack down through the sound hole into the body and insert it into the pre-drilled hole in the tail block.

Using the internal nut (be sure to include the flat and star washers), set the proper depth that will allow the entire smaller threaded section to protrude from the instrument (see figure).

With the jack in place, lay the remaining washer over the threads and attach the external retaining nut until it's tight. Finish by attaching the strap ring (it should cover the retaining nut and washer). Note that asserting too much pressure may crack the finish.

3.2 Pickup installation: Be sure there's a battery inserted into the battery holder. Then plug the strapjack harness into the pickup.

Now loosen the clamp screws on either end of the pickup's top plate until the clamps are open enough to accommodate the guitar's top thickness. Then slide the pickup into the sound hole and tighten the screws. Be sure to secure the wire with the two self-stick wire clips provided so that it does not hit the inside of the guitar during stage movement.

Tighten the screws snugly, but don't overdo it -- this can damage the pickup or guitar finish. If you are concerned about the possibility of the M1 Active damaging the instrument's finish, consider applying thin cork pads (not included) between the clamp and guitar. However, note that the clamps have been left unpadding to improve coupling between the pickup and guitar body. Because the M1 Active reads the top resonances that provide depth and warmth, using cork pads may dampen this sensitivity and adversely affect the pickup's responsiveness.

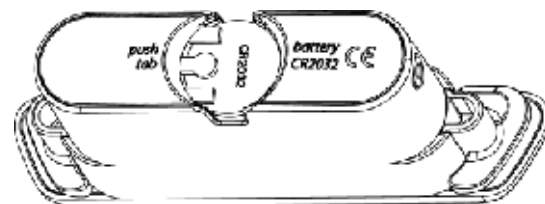
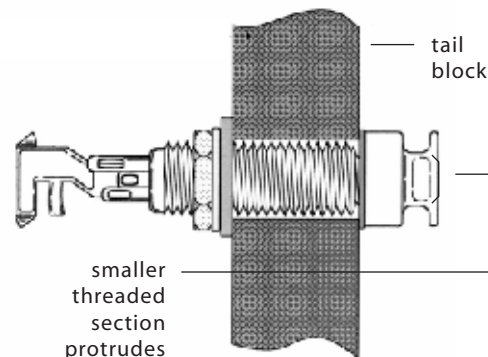

4. USER'S GUIDE

4.1 Plugging in: The M1 Active will plug into practically anything with good results. If you want EQ or use a direct box, our Para D.I. provides both EQ and DI features. Plugging in turns the circuit on and unplugging turns the circuit off. If you want your battery to last a good long time, remember to unplug when you're done.

4.2 Volume control: Yes.

4.3 Replacing the battery: The battery life of the M1 Active is a very long 1000 hours, or about 250 gigs. If you're plugged in 20 hours a week, you'll need to replace your battery once a year. If your battery is going dead you will start to hear some distortion. From the time you hear audible distortion until it's too late, you have several gigs to replace the battery. Press on the center tab over the battery to dislodge the battery. You may need to use a pencil or other tool to press the tab. Lift the battery out from the slots in the side of the pickup, then slide and snap a new one in. Observe polarity. You should be able to read the CR2032 and the "+" designator when the battery is properly installed. These batteries are available at all large drugstores, and sometimes at supermarkets.

4.4 Experimenting with pole piece heights: The pole pieces on the M1 Active are preset (for bronze acoustic strings), but this is just a starting place. They are adjustable with the 3/32" Allen wrench to obtain the optimum balance and tone. The height of the pole pieces relative to the strings will have a profound effect on the sound and balance of the pickup. Raising the pole pieces will increase the output of the strings; lowering them will decrease the output. For the most powerful and articulate sound, we recommend setting the pole pieces closer to the strings. However, if they are too close, they will interfere with the strings' movement and produce a percussive clacking noise. Lowering the pole pieces will deemphasize the strings and emphasize the body sound. We have provided two additional 3/4" pole pieces for use in the B and little E string positions with nickel or electric guitar strings, and one spare 3/8" pole piece for use with acoustic sets that have an unwound "G" string. When adjusting the pole pieces downward you will meet additional resistance when you reach the bottom of the adjustment range. Do not force the pole pieces any further! This could damage the pickup permanently.

4.5 Mixing with other sources: The M1 Active is intended to provide a complete sound from a single pickup. However, you may still want to pair it with another transducer. We have provided for this. The pre-wired strapjack harness has dual output capability. You can connect the output wire from a mini-mic or another transducer to the ring terminal of this jack. Then run a stereo cord to the L.R. Baggs Mixpro or your favorite outboard gear. As with all two-pickup setups, you should experiment with relative phase between pickups if possible. Two sources will often mix much better in one phase than the other.

4. SPECIFICATIONS

Battery type: CR2032

Battery life: 1000+ hours

Current consumption: 135 μ A

Preamp signal to noise: -78dB unweighted

Output level: -10dB

Output impedance: 800 ohms