

ARTcessories™

Creative audio solutions in cool little boxes.

March 2003

MyMONITOR

Personal Monitor Mixer

Problem: A performer needs to hear him/herself through headphones exclusively or mixed with the output of a mixer, CD player, tape deck, or other stereo line level source. Only the mic signal, however, should be going to the main mixer.

Solution: Connect MyMONITOR between the mic and line source, and the mixer. The Mic and line Monitor levels can then be adjusted for mix and volume through the headphones. Only the mic signal will go to the board. And since MyMONITOR can also be battery powered, the unit can be used on a large stage or wherever there is no AC outlet nearby. Dynamic or condenser mics can be used since phantom power would come through the Mic Thru jack from the mixer or other source.

- XLR Mic In connector accepts a dynamic or condenser mic. (The mixer or another source of phantom power will be required for a condenser mic.)
- XLR Mic Thru connector for connecting MyMONITOR to the mixer's mic input.
- 1/4" stereo Monitor In jack accepts the stereo output of a mixer, CD player, tape deck, etc. to be mixed with the mic signal through the headphones. (A mono source can be connected here, but only one earpiece will work.)
- Mic Level control regulates the mic's headphone level.
- Monitor Level control regulates the stereo Monitor inputs level through the headphones.
- Dual stereo headphone outputs. (A friend can listen too.)

Specifications:

- Battery ON/OFF switch
- Power LED
- Maximum Input Level: -20dB mic, 40dB Monitor
- Output Impedance: 10 ohms
- Gain: 15dB 1/4", 50dB XLR
- S/N Ratio: 90dB
- Power: 12V DC (Adapter included) or one 9V battery
- Dimensions: 4.5 x 2.75 x 1.5 inches (112mm x 72mm x 40mm)
- Weight: 1.3lb (590g)

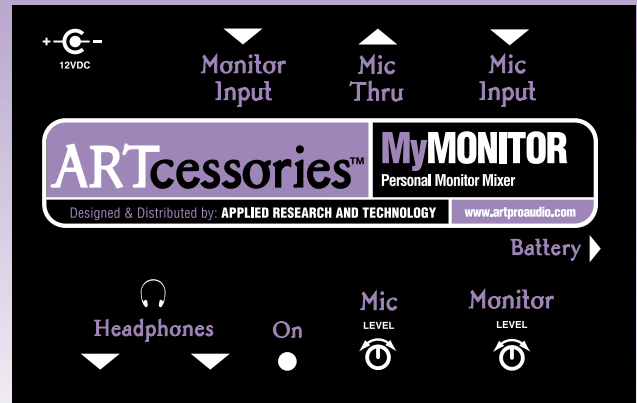

Usage:

- a.) If you are using the AC power adapter (included), connect the cable to the 12V DC connector and plug the other end into a 120V AC power outlet. Otherwise, a 9V battery (optional) can be installed in the battery compartment.
- b.) Set the power switch to the ON position – the Power LED will light up.
- c.) Connect a low impedance dynamic or condenser mic to the Mic In XLR.
- d.) Connect a stereo source to the 1/4" Monitor In jack. If the source is mono, only one earpiece will work.
- e.) Using a low-impedance mic cable, connect the Mic Thru XLR to a mic input on the mixer. If the mic is a condenser, make sure the mixer has phantom power or that you insert a phantom power unit between MyMONITOR and the mixer.
- f.) Connect headphones to one of the Headphones jacks. Another set can be connected to the other jack.
- g.) Adjust the Mic Level and Monitor Level controls for the desired mix and volume through the headphones.

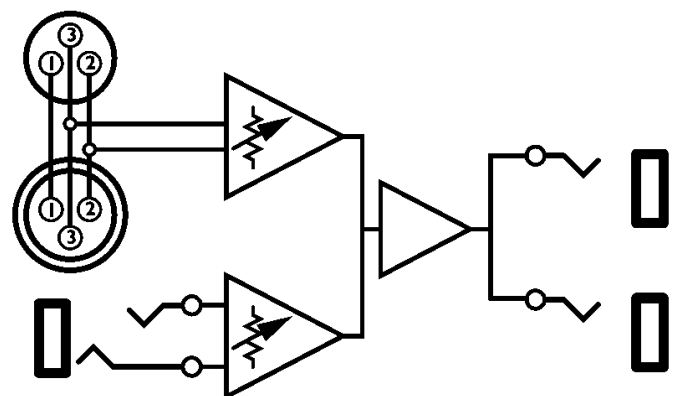

90 DAY
WARRANTY