

# EMG

P.O. BOX 4394  
 SANTA ROSA, CA  
 95402 U.S.A.  
 PH (707) 525-9941  
 FX (707) 575-7046  
 www.emgpickups.com

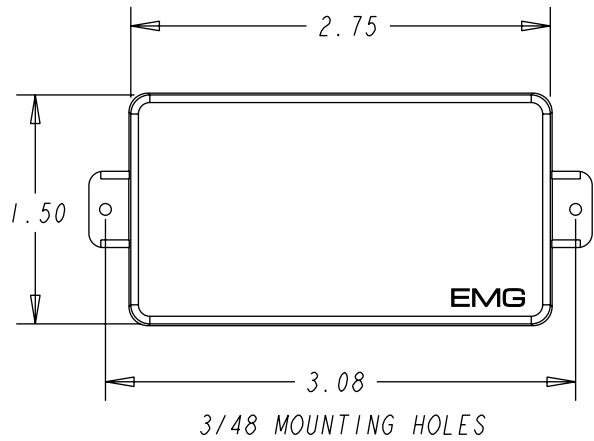

## INSTALLATION INFORMATION

**EMG Models: EMG-H, HA, 58, 60, 60A, 81, 85**

### SPECIFICATIONS:

	H	HA	58	60	60A	81	85
Logo Color	White	Gold	Gold	Grey	Gold	Silver	Gold
Magnet Type	C	A	A/S	C	A	C/S	A
Resonant Frequency (KHz)	4.95	4.45	1.90	2.90	2.20	2.00	2.45
Output Voltage (String)	1.0	1.0	2.8	1.25	1.25	2.0	2.1
Output Voltage (Strum)	1.50	1.50	4.0	3.5	3.75	4.5	4.5
Output Noise@ 60Hz	-90	-91	-91	-89	-91	-91	-89
Output Impedance (Kohm)	10	10	10	10	10	10	10
Current@ 9V (Microamps)	80	80	80	80	80	80	80
Battery Life (Hours)	3000	3000	3000	3000	3000	3000	3000
Maximum Supply (Volts DC)	27	27	27	27	27	27	27

Notes: Magnet Type: A (Alnico) A/S (Alnico/Steel)  
 C (Ceramic) C/S (Ceramic/Steel)

### MODEL:

### IMPORTANT INSTALLATION NOTES:

- Only one battery is required for the pickups, and any active accessories such as the SPC, RPC, EXG, AB, PA-2, and Pi-2.**
- Use an Alkaline or Lithium battery for longest life.
- The controls included with EMG Systems are 25K Ohm, Audio Taper. This value of control is required for the system to work correctly.
- When installing EMG Active Pickups, **DO NOT** connect the bridge ground wire. This wire is usually soldered to a volume or tone control casing and goes to the bridge. This wire grounds the strings and uses them and your body as a shield against hum and buzz. It also creates a shock hazard. EMG Pickups are shielded internally and **DO NOT** require string grounding. This greatly reduces the possibility of reverse polarity shock from microphones and other equipment
- EMG Active Pickups have very little magnetism compared to passive pickups. We recommend you adjust the pickups as close to the strings as possible. Sustain and string movement will not be inhibited by close adjustment.
- If your installation is different from the diagrams in these instructions or you need additional diagrams visit our website: [emgpickups.com](http://emgpickups.com) for a complete listing of available diagrams.

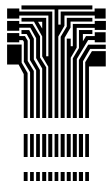

# EMG

P.O. BOX 4394  
 SANTA ROSA, CA  
 95402 U.S.A.  
 PH (707) 525-9941  
 FX (707) 575-7046  
 www.emgpickups.com

### Warranty:

All EMG Pickups and accessories are warranted for a period of two years. This warranty does not cover failure due to improper installation, abuse or damage. If upon examination the pickup is determined to be defective, a replacement will be made at no charge. Warranty replacement products are covered by this same warranty. This warranty covers only those pickups and accessories sold by authorized EMG Dealers. This warranty is not transferable.

**Installation Procedures for Models:  
EMG Models: EMG-H, HA, 58, 60, 60A, 81, 85**

Refer to the following diagrams for the volume, tone configuration for your guitar and follow that diagram. It's recommended that if you plan to install EMG Products that you do the installation per the diagrams included here and get your guitar working before adding accessories.

We recommend you make a simple diagram of your current wiring scheme and follow it when rewiring with the EMG 25K Controls.

Gibson Les Paul Guitars manufactured after April of 1975 have a shield can installed in the control compartment and use long shaft pots. Long shaft 25K pots are available from your dealer or EMG. Refer to diagram 7 for this wiring.

**SPECIAL NOTE:**

The diagrams shown are for EMG Active Pickups only. All diagrams show the Red Wire coming from the pickups connected to the battery. If you are installing EMG-HZ Passive Pickups refer to those diagrams. The Red Wire of the HZ Pickup is NOT for battery power, it is a coil wire.

- 1) Disconnect the existing pickup from its volume and tone control.
- 2) Disconnect any existing selection switch wire(s) from its volume and tone control.

- 3) Remove the pickup and the volume and tone control. Place the EMG volume and tone control in the instrument. Mount the pickup in the mounting ring and install the quick connect cable as shown in the diagram and route the cable to the control cavity.
- 4) Solder the braid of the pickup cable to the case of the volume control as shown in the diagram and connect the switch wires as shown.
- 5) For two-pickup guitars, follow steps 1-4 before continuing.
- 6) Remove the existing output jack and replace it with the EMG output jack. Solder the output wire to the jack as shown in the diagram.
- 7) Solder the RED wire(s) of the pickup(s) to the RED wire of the battery clip and cover the connection with the heat shrink tubing provided.
- 8) Use some of the packaging foam that comes with the pickup and surround the battery to insulate it. Place the battery on the clip and place it securely in the control cavity.
- 9) We suggest you test the guitar before closing up the control cavity to make sure everything is working.

**Be sure to unplug your guitar when not in use to avoid current drain on the battery!**

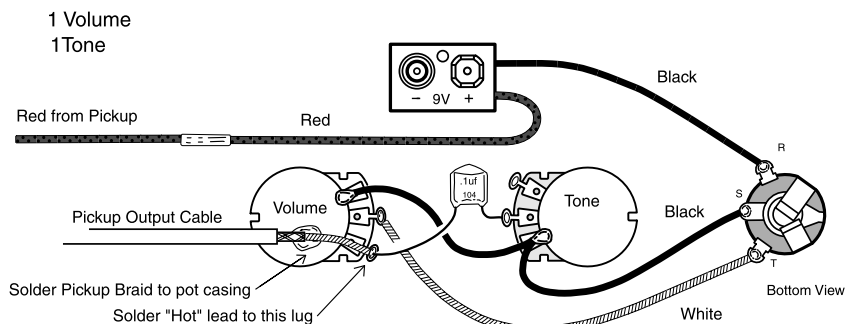
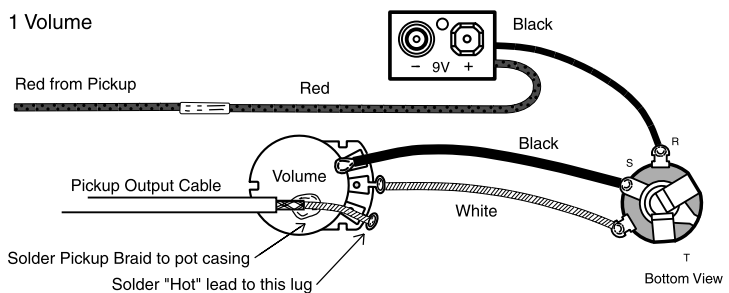
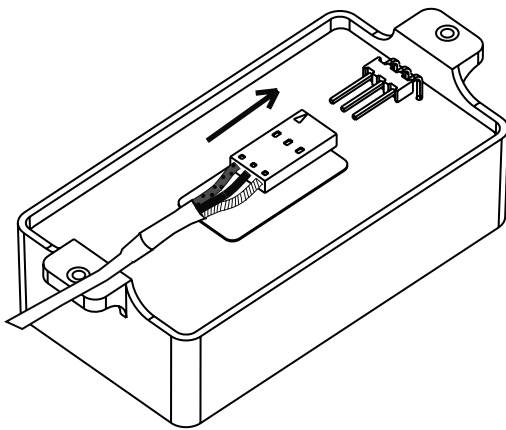

1 Volume,  
1 Tone  
w/ Gibson style toggle switch

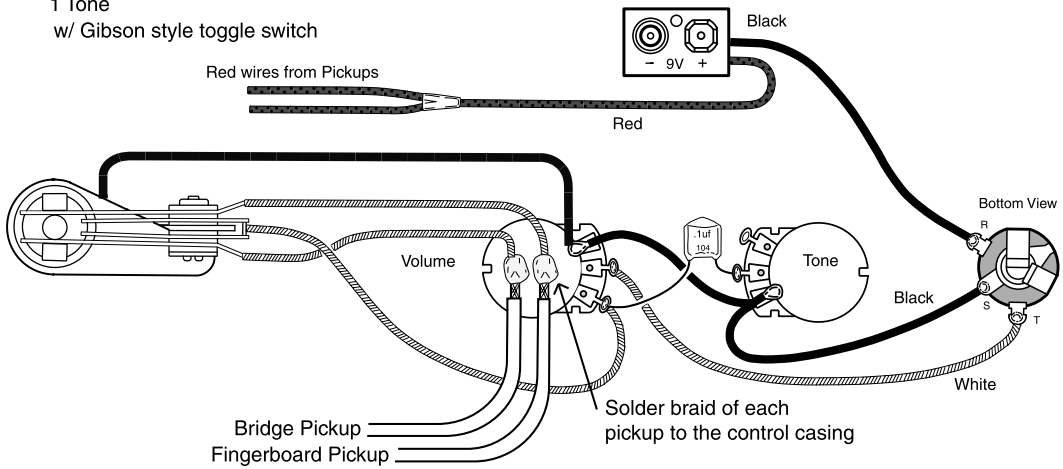

1 Volume,  
1 Tone  
w/ 3 position lever switch

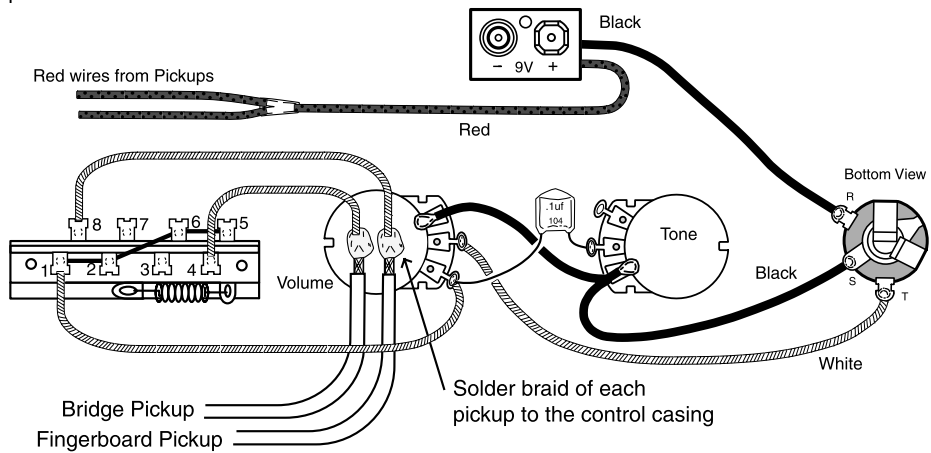

2 Volume (Independent)  
2 Tone  
w/ Gibson Style Toggle Switch

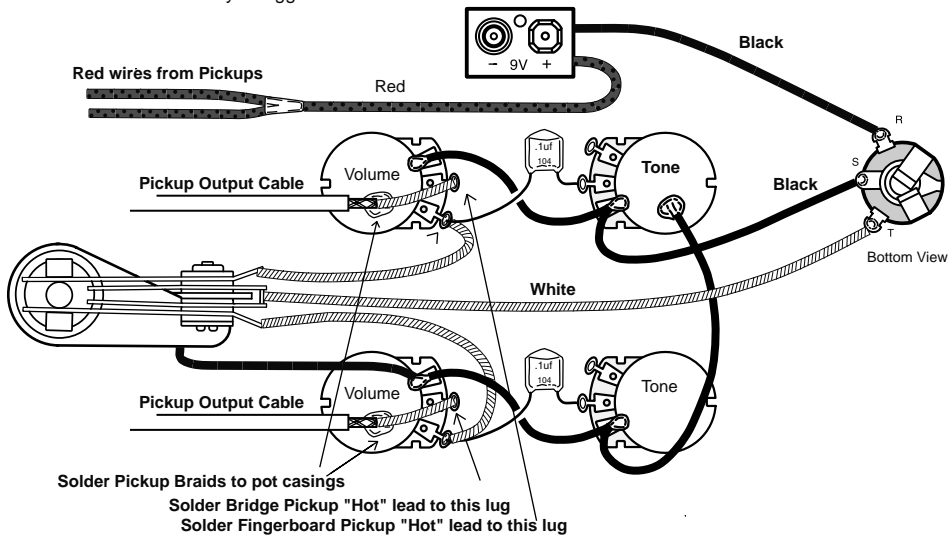

2 Volume (Either volume will act as master)  
 w/ selection switch in middle position)  
 2 Tone  
 w/ Gibson Style Toggle Switch

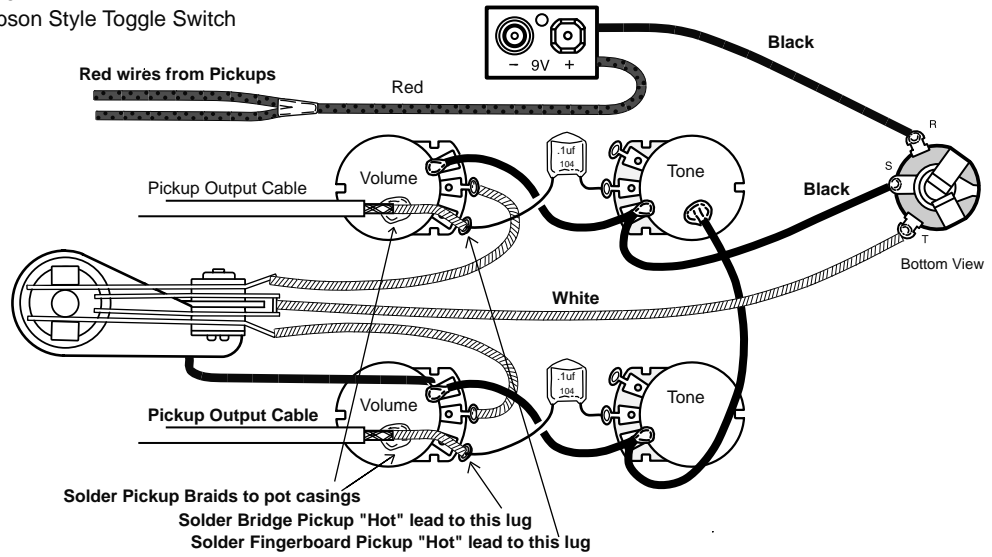

(Gibson Les Paul  
 April 1975 and later)

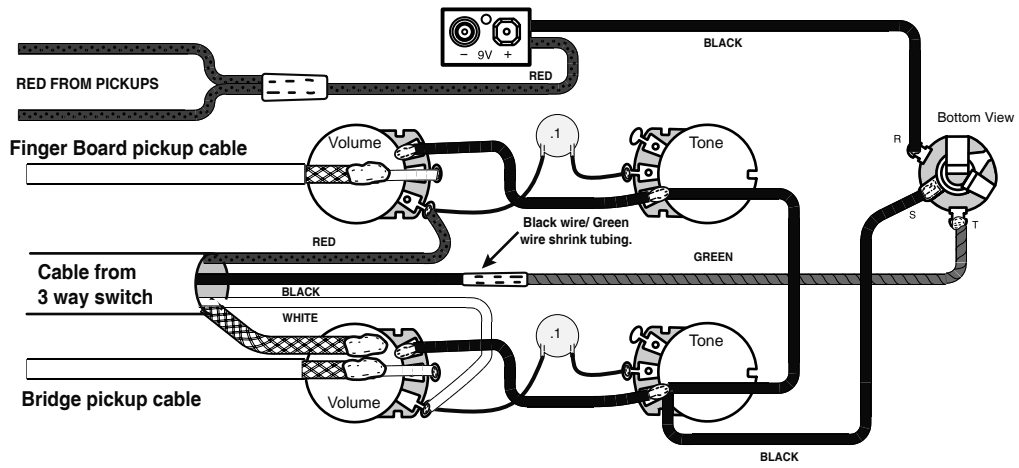

2 Volume (Independent)  
 1 Master Tone  
 w/ Gibson Style Toggle Switch

